

MAC TRAILER MANUFACTURING, INC.

1050-C PNEU MAC TIC DRY BULK

MIKE JOHNSON
252Q
8/12/14 LAST REVISED
DLR REP.:

2016 Spring Dealer Incentive Program Base Model Trailer

SERIAL NO.	#VALUE!
MODEL NO.	TN1050APB
WEIGHT	9534 lb. +/- 3%
DATE	November 3, 2015

VESSEL 192.6712197

GVWR	72 GVWR
MODEL	1050-C
COMMODITY	DRY POWDER AND GRANULES
VESSEL CONSTRUCTION	SMOOTH EXTERIOR - INTERNAL RINGS
LENGTH	42 FT.
OPERATING TEMP	185 DEG - (MAX)
OPERATING PRESSURE	14.7 P.S.I. (HYDRO TESTED TO 22.5 P.S.I.)
VESSEL THICKNESS	.190 ALUMINUM 5454-H32 (STANDARD)
VESSEL FINISH	MILL FINISH - VESSEL (STANDARD)
COMPARTMENTS	SINGLE COMPARTMENT (STANDARD)
LOWER CONES	WELD ON - 45 DEG (STANDARD)
# OF MANHOLES	3
MANHOLE LOCATION	OVER EACH HOPPER
MANHOLE STYLE	BETTS MODEL 8555 20 IN. MANWAY (STANDARD)

PIPING / FITTINGS 9

UNLOAD TYPE	PRESSURIZED
-------------	-------------

AIR INLET LINE

AIR INLET SIZE	3 INCH - INLET, MANIFOLD, VALVE
CHECK VALVES	2-CHECK VALVES (1 @ AIR INLET)-(1UP STREAM OF FRONT HOPPER DISCHARGE)
AIR INLET LOCATION	STREET SIDE FRONT

AERATION

AERATORS	3 PER HOPPER (STANDARD)
AERATION TYPE	B.T.I. SPIN FLOW AERATION KIT @ EACH HOPPER W/ WEAR PLATES
AERATION LINE LOCATION	STREET SIDE
AERATION CONTROL	3" BTI MAXXLIFE BUTTERFLY VALVE
	REGULATES AIR FLOW TO AIR MANIFOLD LINE. 2 INCH - HOSES SUPPLYING AIR TO AERATION SYSTEM.
SEAT	WHITE RUBBER SEAT
DISK	STAINLESS STEEL DISC
HANDLE TYPE	ALUMINUM
HANDLE POSITION PLATE	MANUAL 10-POSITION

PROP / PRES CONTROL VALVE

HOUSING	3" BTI MAXXLIFE BUTTERFLY VALVE
SEAT	WHITE RUBBER SEAT
DISK	STAINLESS STEEL DISC
HANDLE TYPE	ALUMINUM
HANDLE POSITION PLATE	MANUAL 10-POSITION

BLOW DOWN LINE

HOUSING	3" BTI MAXXLIFE BUTTERFLY VALVE
SEAT	WHITE RUBBER SEAT
DISK	STAINLESS STEEL DISC
HANDLE TYPE	ALUMINUM
HANDLE POSITION PLATE	MANUAL 10-POSITION
RELIEF PRESSURE	15 P.S.I.
BLOW DOWN LOCATION	STREET SIDE FRONT

TOP AIR

TOP AIR	NONE	PORTS FOR FUTURE TOP AIR INSTALLATION
TOP LINE LOCATION	NONE	

PRODUCT VALVE

PRODUCT VALVE SIZE	NONE	INSTALL 5" BUTTERFLY VALVE FLANGES ON BOTTOM OF HOPPER
HOUSING	NONE	
SEAT	NONE	
DISK	NONE	
HANDLE TYPE	NONE	
HANDLE POSITION PLATE	NONE	

PRODUCT TEE

PRODUCT TEE TYPE	NONE
------------------	------

PRODUCT LINE

LINE	NONE
CONNECTIONS	NONE
	NONE
REAR DISCHARGE	NONE
DISCHARGE LOCATION	NONE
GAUGE ENCLOSURE	1
GAUGES	1 - LINE P.S.I. / 1 - TANK P.S.I. - (INSIDE ILLUMINATED ENCLOSURE)
GAUGE LOCATION	STREET SIDE - REAR - FORWARD OF TANDEM (STANDARD)

MAC TRAILER MANUFACTURING, INC.

1050-C PNEU MAC TIC DRY BULK

MIKE JOHNSON
252Q
8/12/14 LAST REVISED
DLR REP.:

2016 Spring Dealer Incentive Program Base Model Trailer

SERIAL NO.
MODEL NO.
WEIGHT
DATE
BN-1

#VALUE!
TN1050APB
9534 lb. +/- 3%
November 3, 2015

ACCESSORIES 15

LADDER	LADDER AT REAR - DOUBLE HAND RAIL (STANDARD)	
WALKWAY	ADHESIVE BACKED SKID RESISTANT TAPE BETWEEN TOERAILS (STANDARD)	HOSE HANGER INCLUDED WITH COUPLER
HAND RAIL	NONE	
TOE RAIL	FULL LENGTH - BOTH SIDES (STANDARD)	
HOSE TUBE	NONE	
HOSE TROUGH	NONE	DOCUMENT HOLDER INCLUDED
TIRE CARRIER	NONE	
FENDERS	ALUMINUM ROLLED EDGE - SINGLE CONTOUR AT FRONT, DOUBLE CONTOUR AT REAR (STANDARD)	
MUD FLAPS	ANTI-SAIL FLAPS - REAR OF FRONT FENDERS AND REAR OF BACK FENDERS (STANDARD)	
TOW HOOK	NONE	

CHASSIS 34

MODEL TYPE	TANDEM	
5TH WHEEL LOCATION	GALVANIZED, ADJUSTABLE	
5TH WHEEL HEIGHT	48 IN.	
LANDING GEAR	JOST - 5 YEAR NO LUBE - D.S. (STANDARD)	
SUSPENSION	HEND. INTRAAX AAT 230 W/ RAISED AXLE - TP SPINDLE	
AXLES	71.5" AXLES	
WHEEL END PACKAGE	NONE	
SUSPENSION CONTROLS	AUTOMATIC DUMP ON EMERGENCY GLADHAND (STANDARD)	
SCALE SYSTEM	LOAD GAUGE - STREET SIDE REAR (STANDARD)	
HUBS & DRUMS	CENT W/DURALITE HUB. HP OB 10 STUD TP. LS, 7 INCH (STANDARD)	
TIRE & RIM SIZE	22.5 INCH - TIRES & RIMS (STANDARD)	
TIRE TYPE	8 - BF GOODRICH ST230 11R 22.5 16 PLY (STANDARD)	
RIM TYPE	ALCOA HP 22.5X8.25 10 HOLE MILLED	
TIRE INFLATION SYSTEM	NONE	
A.B.S.	(1) 4S2M MERITOR / WABCO (STANDARD)	
BRAKE SHOES	7" XL, W/30-30 CHAMBERS (STANDARD)	
SLACKS	GUNITE (STANDARD)	
HUBODOMETER	NONE	
SYNTHETIC LUBRICATION	NONE	

LIGHTS 0

REAR I.D. LIGHTS	(I.D.) (I.D.) (I.D.)	
"HIGH MOUNT" BRAKE LIGHT	DUAL FUNCTION REAR I.D. LIGHTS BRIGHTEN WHEN BRAKES ARE APPLIED	
REAR LIGHT PANEL	(TURN) (STOP) (STOP) - (STOP) (STOP) (TURN)	
LIGHT TYPE	GROTE LED W/GROMMETS (STANDARD)	
MARKER LIGHTS	2 EACH SIDE - FRONT AND REAR (STANDARD)	
MIDTURNS	2-PAIR COMBO MIDTURNS (STANDARD)	
BACK-UP LIGHTS	NONE	
WORK LIGHTS	NONE	
AUXILARY CABLE (4 OR 7 WAY)	NONE	

PAINT 2

SUSPENSION COATING	GALVANIZED HANGERS WITH HENDRICKSON BLACK SOFT COAT	
PAINT COLOR	MAC BLACK (STANDARD)	

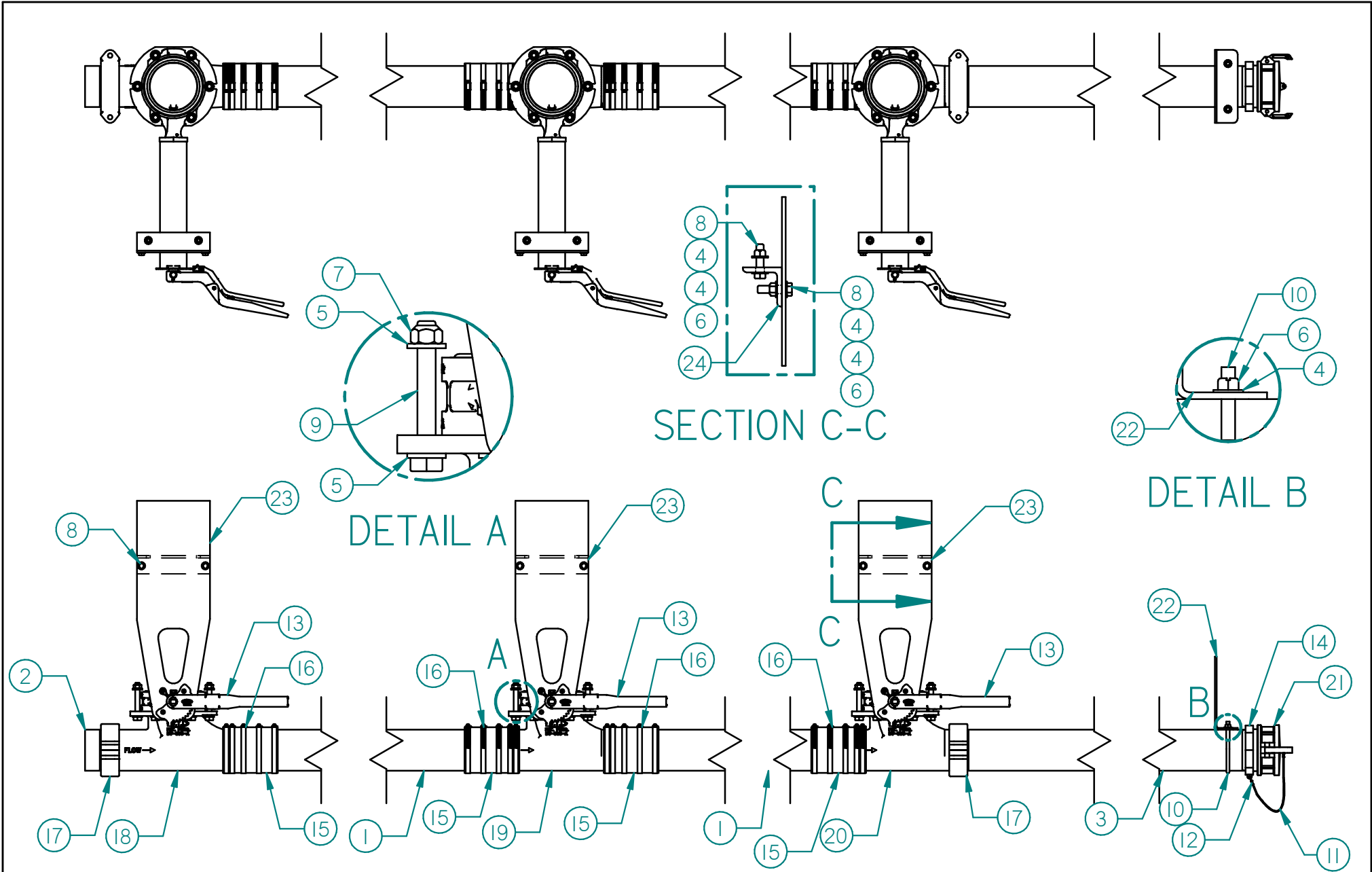

THIS DRAWING IS THE PROPERTY OF MAC MANUFACTURING INC. AND SUBJECT TO RECALL AT ANY TIME. DUPLICATION OR DISTRIBUTION WITHOUT PERMISSION IS PROHIBITED.

MAC MANUFACTURING INC.

UNLESS OTHERWISE SPECIFIED DIMENSIONS ARE IN INCHES ANGLES ±2° FRACTIONS ±1/16" DECIMALS ±0.02

CEMENT DISCH RETROFIT KIT 1050

1	11/30/15	RELEASED TO PRODUCTION	N/A	CAB
REV.	DATE	REASON FOR CHANGE	ECN #	BY

DRAWN: CAB	DATE: 11/30/15
WEIGHT: 181.5 lbm	PAGE 1 OF 5

PART # : 73803000

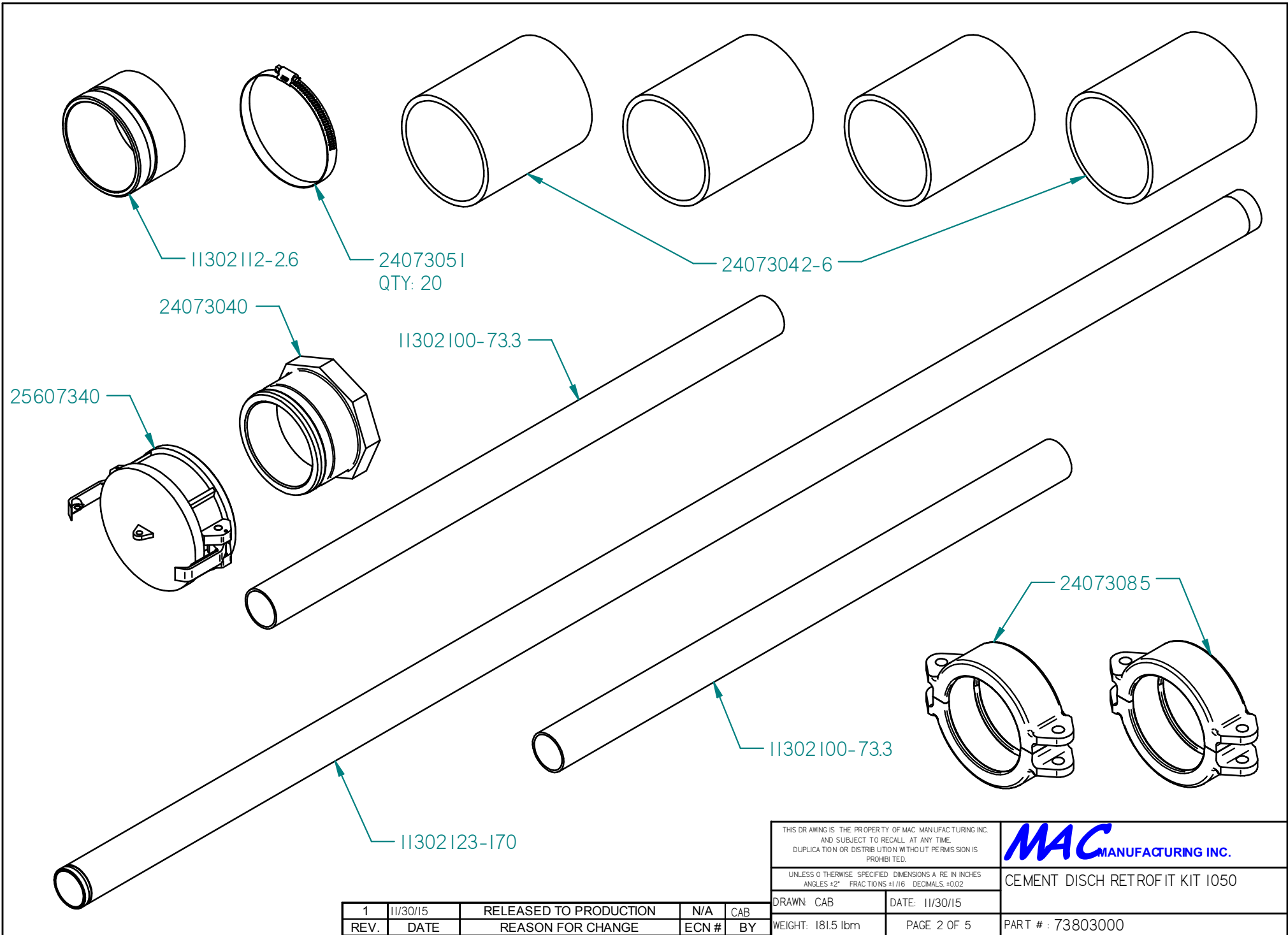

THIS DRAWING IS THE PROPERTY OF MAC MANUFACTURING INC. AND SUBJECT TO RECALL AT ANY TIME. DUPLICATION OR DISTRIBUTION WITHOUT PERMISSION IS PROHIBITED.		MAC MANUFACTURING INC.	
UNLESS OTHERWISE SPECIFIED DIMENSIONS ARE IN INCHES ANGLES ±2° FRACTIONS ±1/16 DECIMALS ±0.02		CEMENT DISCH RETROFIT KIT 1050	
DRAWN: CAB	DATE: 11/30/15		
WEIGHT: 181.5 lbm	PAGE 2 OF 5	PART #: 73803000	

1	11/30/15	RELEASED TO PRODUCTION	N/A	CAB
REV.	DATE	REASON FOR CHANGE	ECN #	BY

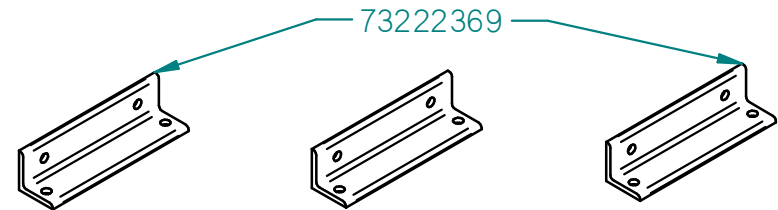
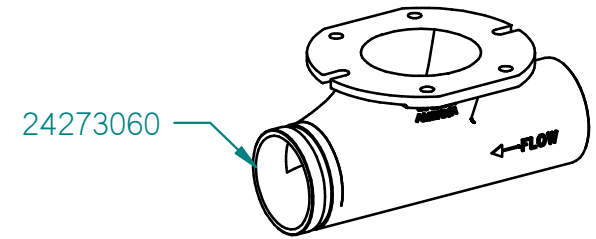
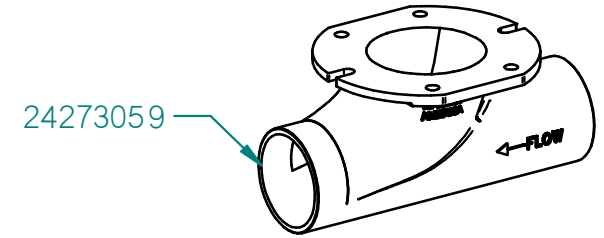
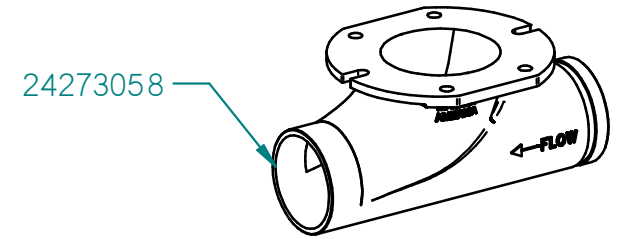
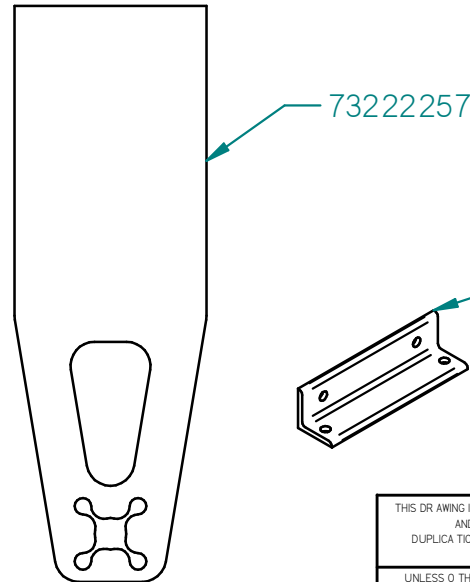
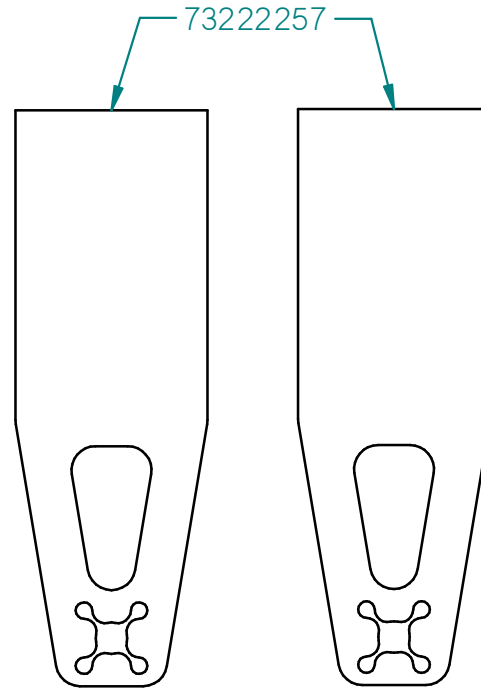
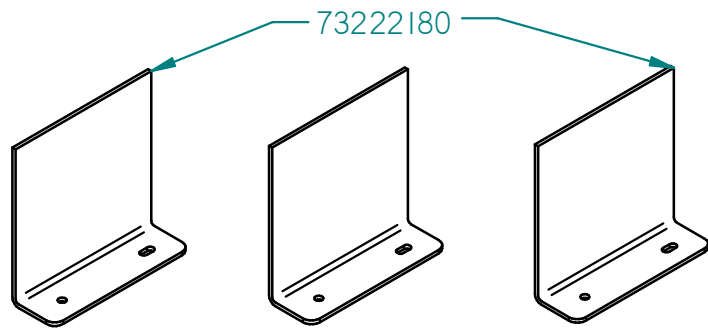
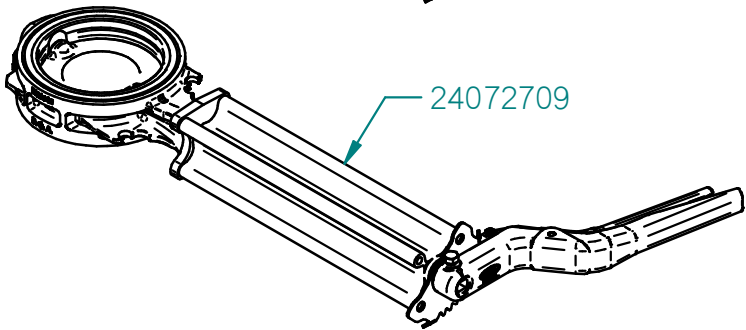
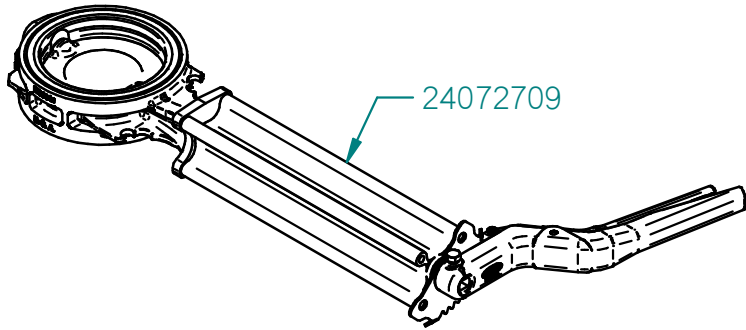
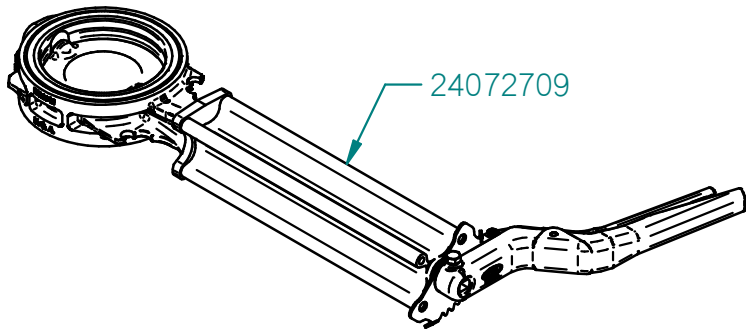

THIS DRAWING IS THE PROPERTY OF MAC MANUFACTURING INC. AND SUBJECT TO RECALL AT ANY TIME. DUPLICATION OR DISTRIBUTION WITHOUT PERMISSION IS PROHIBITED.

MAC MANUFACTURING INC.

UNLESS OTHERWISE SPECIFIED DIMENSIONS ARE IN INCHES ANGLES ±2° FRACTIONS ±1/16" DECIMALS ±0.02

CEMENT DISCH RETROFIT KIT 1050

1	11/30/15	RELEASED TO PRODUCTION	N/A	CAB
REV.	DATE	REASON FOR CHANGE	ECN #	BY

DRAWN: CAB

DATE: 11/30/15

WEIGHT: 181.5 lbm

PAGE 3 OF 5

PART #: 73803000

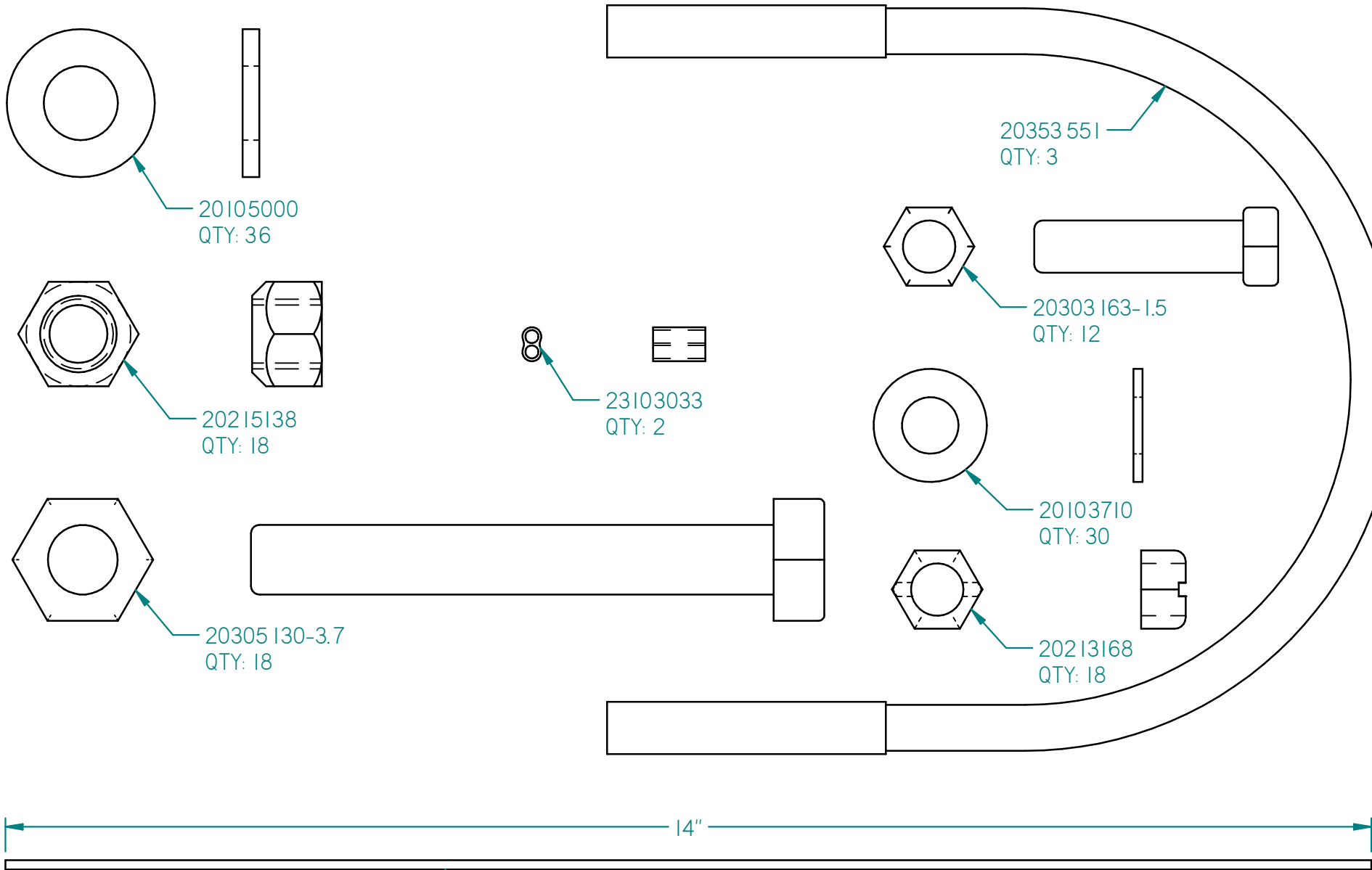

THIS DRAWING IS THE PROPERTY OF MAC MANUFACTURING INC. AND SUBJECT TO RECALL AT ANY TIME. DUPLICATION OR DISTRIBUTION WITHOUT PERMISSION IS PROHIBITED.		MAC MANUFACTURING INC.	
UNLESS OTHERWISE SPECIFIED DIMENSIONS ARE IN INCHES ANGLES ±2° FRACTIONS ±1/16 DECIMALS ±0.02		CEMENT DISCH RETROFIT KIT 1050	
DRAWN: CAB	DATE: 11/30/15		
WEIGHT: 181.5 lbm	PAGE 4 OF 5	PART # : 73803000	

1	11/30/15	RELEASED TO PRODUCTION	N/A	CAB
REV.	DATE	REASON FOR CHANGE	ECN #	BY

PARTS LIST FOR 73803000

ITEM	QTY.	PART No.	DESCRIPTION	WEIGHT
1	2	11302100-73.3	PIPE, 4" SCH 40 ALUM	45.6 lbm
2	1	11302112-26	PIPE, 4" SCH40 ALUM, PLN/GRV	0.8 lbm
3	1	11302123-170	PIPE, 4" SCH40 ALUM, GRV/THD	52.3 lbm
4	30	20103710	WASHER, 3/8" STAINLESS	0.2 lbm
5	36	20105000	WASHER, 1/2" SAE ZINC	3.6 lbm
6	18	20213168	LOCKNUT, 3/8-16 GR 8	0.2 lbm
7	18	20215138	LOCKNUT 1/2"-13 ZINC	0.8 lbm
8	12	20303163-1.5	HHCS, 3/8-16 X 1 1/2" STAINLESS	0.8 lbm
9	18	20305130-3.7	BOLT, HHCS 1/2-13 x 3-3/4" LG. GRADE 8	5.0 lbm
10	3	20353551	U-BOLT - 3/8-16 X 4.5" STAINLESS	1.1 lbm
11	1	23103032-14	3/32" X 14" WIRE ROPE	0.0 lbm
12	2	23103033	WIRE CRIMP	0.0 lbm
13	3	24072709	5" BTI BUTTERFLY VALVE SS/DISC, 14" EXT HD HANDLE	0.0 lbm
14	1	24073040	COPUPLER - 4" AL, GROOVED W/ FEM THREAD	1.5 lbm
15	4	24073042-6	HOSE 4.5" ID, RUBBER CLAMP	3.0 lbm
16	20	24073051	HOSE CLAMP, SST 5 1/2", WORM GEAR	0.0 lbm
17	2	24073085	VICTAULIC CLAMP, 4" BOLT ON	7.6 lbm
18	1	24273058	HOPPER TEE, ALUM, 5 X 4 SIPHON FLOW STRAIGHT GRV/PLN	7.2 lbm
19	1	24273059	HOPPER TEE, ALUM, 5 X 4 SIPHON FLOW STRAIGHT PNL/PLN	6.8 lbm
20	1	24273060	HOPPER TEE, ALUM, 5 X 4 SIPHON FLOW STRAIGHT PLN/GRV	6.7 lbm
21	1	25607340	DUST CAP, 4" ALUM	1.7 lbm
22	3	73222180	4" PIPE BRACKET, SIDE	4.5 lbm
23	3	73222257	BRKT, HANDLE EXT SUPPORT, 14"	8.4 lbm
24	3	73222369	ANGLE, EXTENSION SUPPORT MOUNT	2.1 lbm